

Data sheet

**M12 Industrial Ethernet cable, D-coded, 15.0 m,
M12 plug straight - RJ45 plug straight,
drag chain, torsion, PUR**

Page 1/7

P/N
142M4D15150
EAN 4250184190257
2025/09/17
Version: N

Illustrations



Dimensional drawing

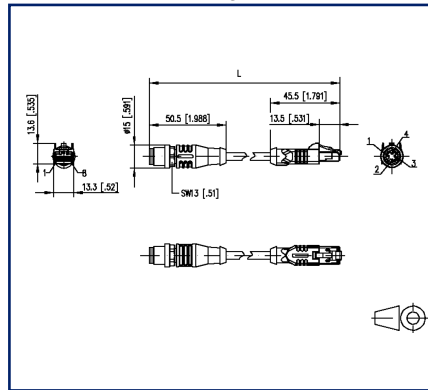

Wiring diagram

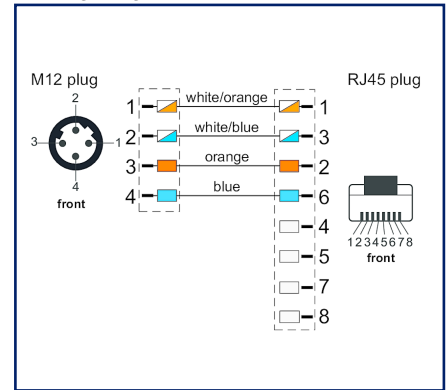

See enlarged drawings at the end of document

Product specification

Shielded Ethernet cable made of PUR for safe and industrial data transmission in automation and fieldbus technology. Real-time requirements based on IEC61158 can be realized. The cable meets the requirements of UL-Style 21815 (80°/300V) and the specifications of Cat5 (electrical properties based on EN50288-2-2). Materials and design for increased mechanical stress (abrasion, bending, vibration, etc.) of the cable. Can be used in drag chain operation/torsion. High tensile strength due to incorporated Kevlar thread. Special properties: seawater resistant, recyclable, LABS free, RoHs compliant, acid and alkali resistant, ozone resistant, UV resistant, hydrolysis resistant, drag chain compatible, halogen free, oil resistant, high flexibility, microbe resistant.

- Standard variants: 1.0 m, 2.0 m, 5.0 m, 10.0 m.
- Other cable lengths on request.



Data sheet

**M12 Industrial Ethernet cable, D-coded, 15.0 m,
M12 plug straight - RJ45 plug straight,
drag chain, torsion, PUR**

P/N
142M4D15150
EAN 4250184190257
2025/09/17
Version: N

Technical Data

General Data

Fields of application	Industrial Ethernet
Design	Ethernet-Connection line
Shielding	shielded
Transmission technology	Copper
Cable Type	S/UTP
Number of twisting elements	4
Twisting element	single core
Wiring	Profinet
Color coding fiber/ wire(s)	white/orange, white/blue, orange, blue
Color	green
Dimensions	
Dimension - Interface 1 (L x W x H)	50.5 mm x 15 mm x 15 mm
Dimension - Interface 1 (L x W x H)	1.988 in. x 0.591 in. x 0.591 in.
Dimension - Interface 2 (L x W x H)	45.5 mm x 13.3 mm x 13.6 mm
Dimension - Interface 2 (L x W x H)	1.791 in. x 0.524 in. x 0.535 in.
Cable length (m)	15 m
Cable length (ft)	49.21 ft
Labeling option	identification label carrier

Transmission characteristics

Category (ISO)	5e
Transmission rate up to 100 MBit (Fast Ethernet)	IEEE 802.3u

Connections/interfaces

Connector technology interface 1	M12-plug
Connector technology interface 2	RJ45 plug
Coding interface 1	D-coded
Number of positions/contacts interface 1	4
Number of positions/contacts interface 2	8P/4C

Data sheet

**M12 Industrial Ethernet cable, D-coded, 15.0 m,
M12 plug straight - RJ45 plug straight,
drag chain, torsion, PUR**

P/N
142M4D15150
EAN 4250184190257
2025/09/17
Version: N

Technical Data

Connections/interfaces

Termination data, stranded wire (min. - max.)

Conductor cross section, stranded wire	AWG 26/19
Conductor diameter, stranded wire (bare copper)	0.5 mm
Conductor diameter, stranded wire (bare copper)	0.02 in.
Cable sheath diameter (min. - max.)	
Cable sheath diameter	4.8 mm
Cable sheath diameter	0.189 in.

Electrical characteristics

Current carrying capacity	1 A at 40 °C
Rated voltage	60 V DC
Insulation resistance	min. 100 MOhm

Mechanical data

Life - Number of mating cycles	min. 100
Torsion	min. ± 30 °/m
Bending radius without load	min. 36 mm
Maximum operating bending radius	19.2 mm
Maximum operating bending radius	0.748 in.
Maximum installation load	36 mm
Maximum installation load	1.417 in.
Number of alternating bending cycles (mechanical resistance) at:	5 million bending cycles
Alternating bending radius	36 mm
velocity	180 m/s
acceleration	5 m/s ²
Shielding braid coverage	85 %

© 2025 METZ CONNECT - Technische Änderungen vorbehalten! Subject to modifications! Sous réserve de modifications techniques!

Data sheet

**M12 Industrial Ethernet cable, D-coded, 15.0 m,
M12 plug straight - RJ45 plug straight,
drag chain, torsion, PUR**

P/N
142M4D15150
EAN 4250184190257
2025/09/17
Version: N

Technical Data

Materials and material properties

Material - Conductor	Cu (copper)
Material - Conductor Insulation	polypropylene
Material - Cable jacket	PUR
Material - Body interface 1	Plastics
Material - Body interface 2	Plastics
Material - Contact interface 1	CuSn
Material - Contact interface 2	CuSn
Material - Contact finish interface 1	Au (gold)
Material - Contact finish interface 2	Au (gold)
Material - Contact carriers interface 1	Plastics
Material - Contact carriers interface 2	Plastics
Material - Union nut interface 1	CuZnPb (brass)
Material - Union nut finish interface 1	Ni (nickel)
Material - Pair shield	plastic film
Material - Pair shield finish	Al (Aluminium)
Material - Main shield	Cu (copper) braid
Material - Main shield finish	Sn
Flame retardancy	yes
Halogen free	yes
Oil resistance	yes
UV-resistance	yes
drag chain suitable	yes
torsional	yes
RoHS	compliant

Environmental conditions

Temperature (min. - max.)	
Temperature - Operating °C	-30 °C - 70 °C
Temperature - Operating °F	-22 °F - 158 °F
Particulate ingress interface 1	IP6X when plugged in
Liquid ingress/immersion interface 1	IPX5, IPX7, IPX8 when plugged in
Particulate ingress interface 2	IP2X when plugged in
Liquid ingress/immersion interface 2	IPX0 when plugged in

Data sheet

**M12 Industrial Ethernet cable, D-coded, 15.0 m,
M12 plug straight - RJ45 plug straight,
drag chain, torsion, PUR**

P/N
142M4D15150
EAN 4250184190257
2025/09/17
Version: N

Technical Data

Environmental conditions	
Pollution degree interface 1	3
Pollution degree interface 2	1
Approvals	
UL listed (file no.)	DUXR.E178484
Standards/Regulations	
Generic cabling systems	
General requirements	ISO/IEC 11801-1 DIN EN 50173-1
Profinet	yes
Connectors for electronic equipment	
circular connector	DIN EN 61076-2-101
Multi-element metallic cables used in analogue and digital communication and control	DIN EN 50288-4-1
Test for vertical flame propagation for a single insulated wire or cable	IEC 60332-1-2
Measurement of smoke density of cables burning	DIN EN 61034
Classifications	
ETIM 7.0	EC002599
ETIM 8.0	EC002599
ETIM 9.0	EC002599
ETIM 10.0	EC002599

Packing details	
Type of packaging	1 pc(s) / plastic bag

Application note

This product is a standard product of METZ CONNECT. METZ CONNECT is not aware of the specific intended use of the goods by the Customer or any customers of the Customer. The Customer guarantees that it has fully and sufficiently tested the use of the goods and any product modifications, product changes or product enhancements with regard to the specific intended use in accordance with the state of the art or in any other way. At METZ CONNECT's request, the Customer shall submit and make available meaningful evidence (e.g. test and laboratory protocols, certifications, etc.).

Data sheet

Page 6/7

**M12 Industrial Ethernet cable, D-coded, 15.0 m,
M12 plug straight - RJ45 plug straight,
drag chain, torsion, PUR**

P/N
142M4D15150
EAN 4250184190257
2025/09/17
Version: N

Illustrations

Dimensional drawing

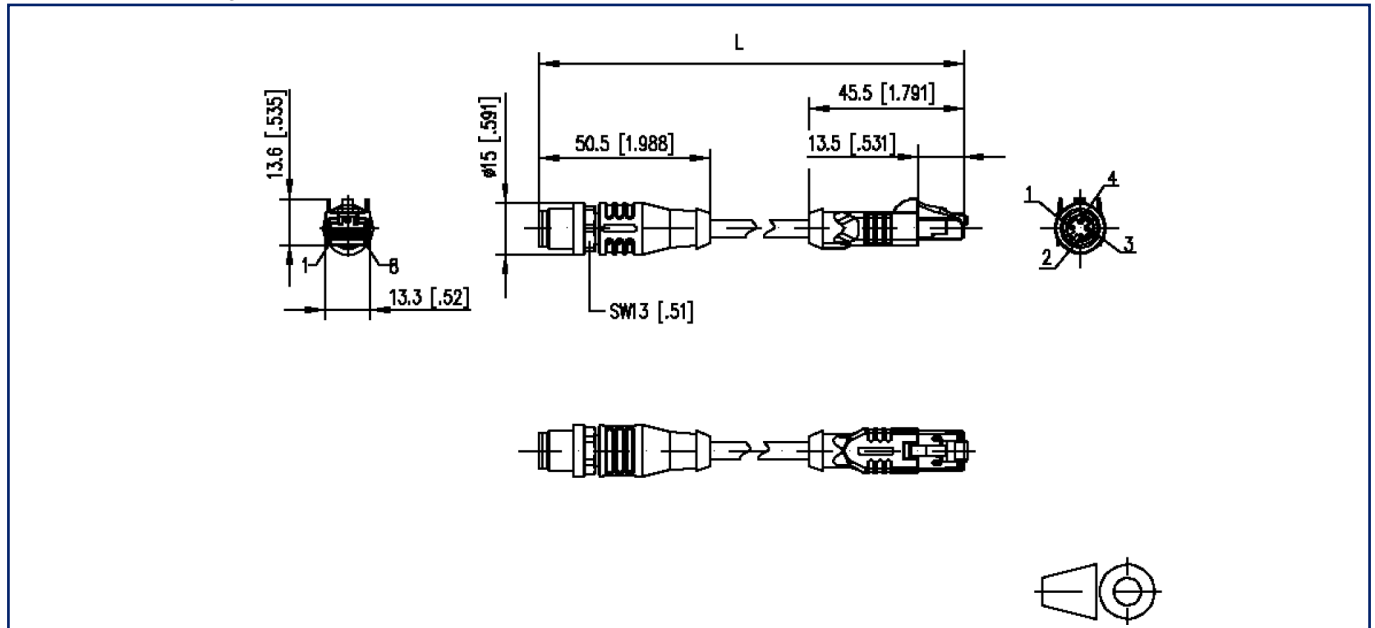

Wiring diagram

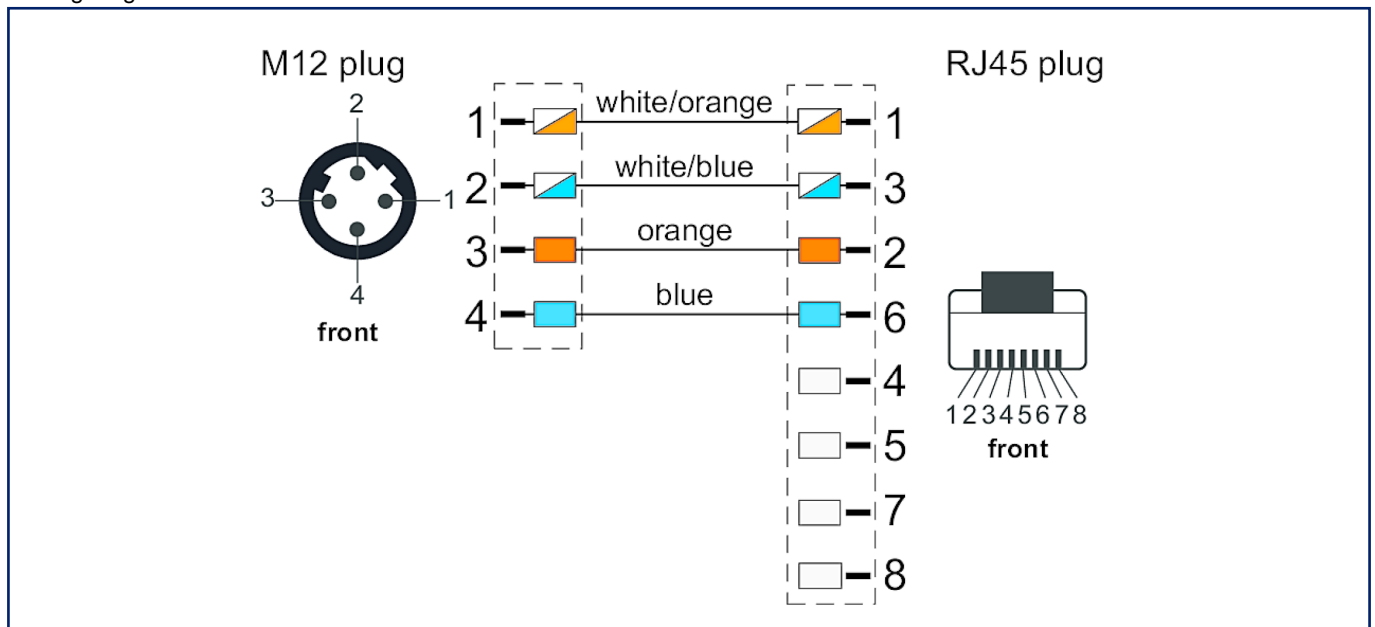

Data sheet

Page 7/7

**M12 Industrial Ethernet cable, D-coded, 15.0 m,
M12 plug straight - RJ45 plug straight,
drag chain, torsion, PUR**

P/N

142M4D15150

EAN 4250184190257

2025/09/17

Version: N

Illustrations

Principle diagram

